

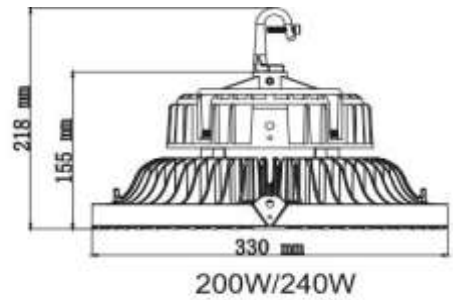

昕燁達科技有限公司

High Bay HBR100/150/200/240 series

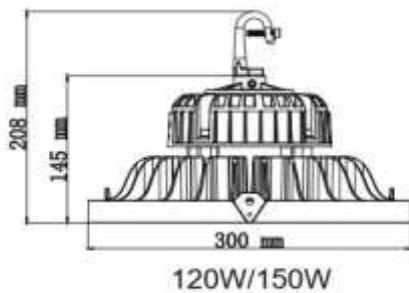
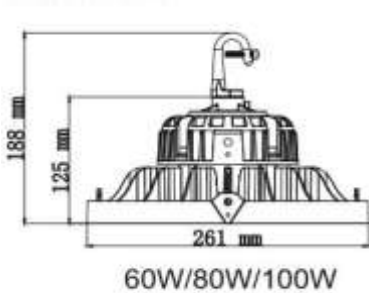
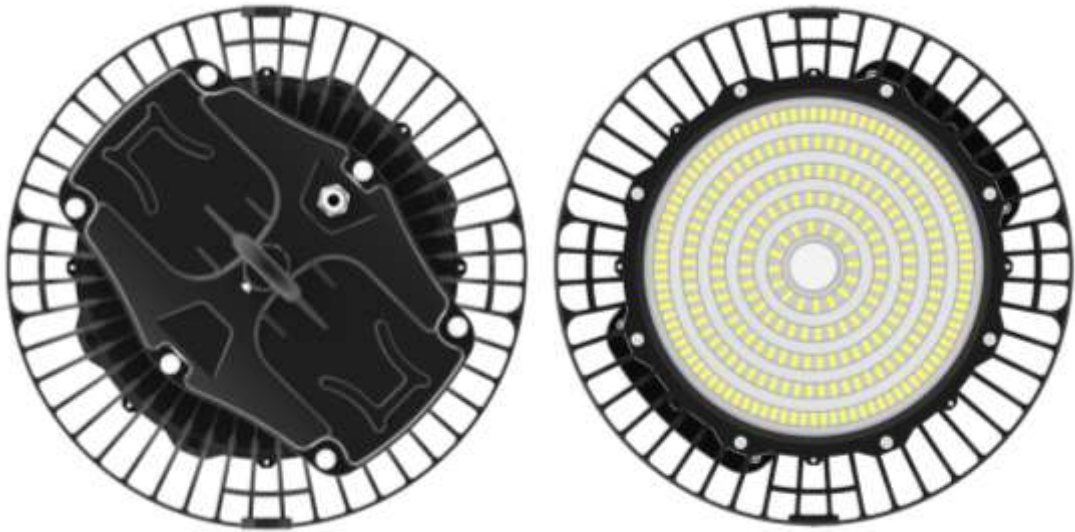

Features

- IP65 protections rating ; for indoor&outdoor using
- Energy Efficiency Grade: A+
- Quick Start instant 100% luminous flux
- **2 Year Warranty** on complete fixture. (LED's, Driver, & Housing)
- Certificate: CE,RoHs,ETL,DLC,SAA,TUV (Pending)
- Body: Aluminium alloy
- Stainless steel screws High Output LED's,up to **150m/W standard**
- High CRI >80
- UL listed Meanwell driver,High PF>0.96 low THD driver,Flicker free
- Environmentally friendly, no mercury, No UV, No IR
- **60°/90°/ 120°for option**

Specifications

Model	HBR100C	HBR150	HBR200	HBR240
Power	100W	150W	200W	240W
CCT	5500K			
CRI	>80			
Power Factor	>0.9			
IP	65			
Input voltage	AC100~277V			
Luminus Flux	130~150Lm/W			
Beam Angle	60°/90°/120°			
Working Temp.	-20°C~50°			
Diameter	261mm	300mm	330mm	
Hight	188mm	208mm	218mm	
Net Weight	2.9KG	3.9KG	5.9KG	
Gross Weight	3.7KG	4.9KG	7.0KG	
Quantity/Carton	1PCS/Carton			
Size/Carton	325*325*225	370*370*240	400*400*250	
Certifications	CE/FCC/RoHS/TUV/cUL/ETL/IP65			
Warranty	2Y			

Note

5000K/6000K customized production is acceptable.